

# ASSEMBLY INSTRUCTIONS

ITEM: #3208

## CONGRATULATIONS

You've purchased a fine product. All of our easy - to-assemble products are designed and carefully tested to meet the highest quality standards - Yours. We've included simple step-by-step instructions to help you recommend that you follow the steps below.

1. Please read the instructions thoroughly
2. Identify all parts and hardware, and
3. Gather the tool(s) necessary

NOTE: Do not tighten screws until unit is fully assembled. Only then tighten all screws.

## PARTS INFORMATION

To protect your parts during assembly

## CARE INSTRUCTIONS

To clean surface use only water on a damp cloth. Do not use window cleaners or cleaning abrasives as it will scratch the surface and could damage the protective coating.

## PARTS LIST

REF.	PART NAME	QUANTITY
A	Top Board	1
B	Top middle cross Board	1
C	Down middle cross Board	1
D	Middle-Vertical Board of Top Layer	1
E	Middle-Vertical Board of Middle Layer Left	1
F	Right Side Board	1
G	Left Side Board	1
H	Back Lower Crosspiece	1
I	U Bracket Support Rail	1
J	Backboard	1
K	Footboard	1
L	Side Rail	2
M	Slat	1
N	High Leg Support	3
O	Small Leg Support	3
P	Center Rail	1
Q	Front Lower Middle Horizontal Board	1
R	Middle-Vertical Board of Middle Layer Right	1

## HARDWARE AND TOOLS DIAGRAM

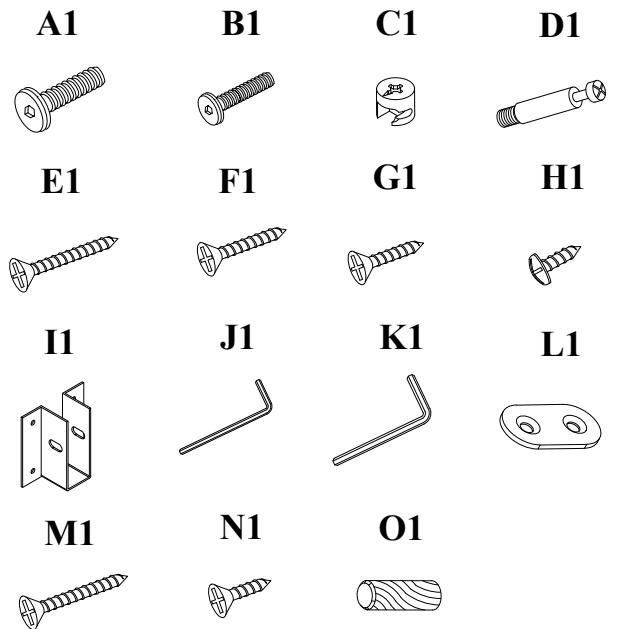

A1	Barrel Bolts	D8x20	8
B1	Barrel Bolts	D6x35	24
C1	Nut		4
D1	Fitting Bolt	D6.5x44	4
E1	Wood Screw	D4x30	54
F1	Wood Screw	D4x25	4
G1	Wood Screw	D4x20	12
H1	Wood Screw	D4x20	30
I1	U Bracket		2
J1	Hex Key M4		1
K1	Hex Key M5		1
L1	Bracket		2
M1	Wood Screw	D4x40	2
N1	Wood Screw	D4x15	4
O1	Wooden Dowel	D10x30	3

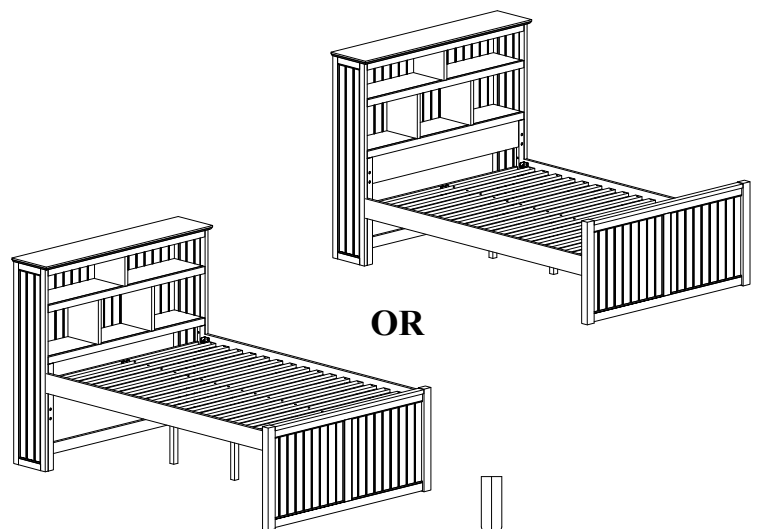

OR

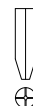

Note: You will also need a Philips Screwdriver (not included)

# ASSEMBLY INSTRUCTIONS

## STEP 1

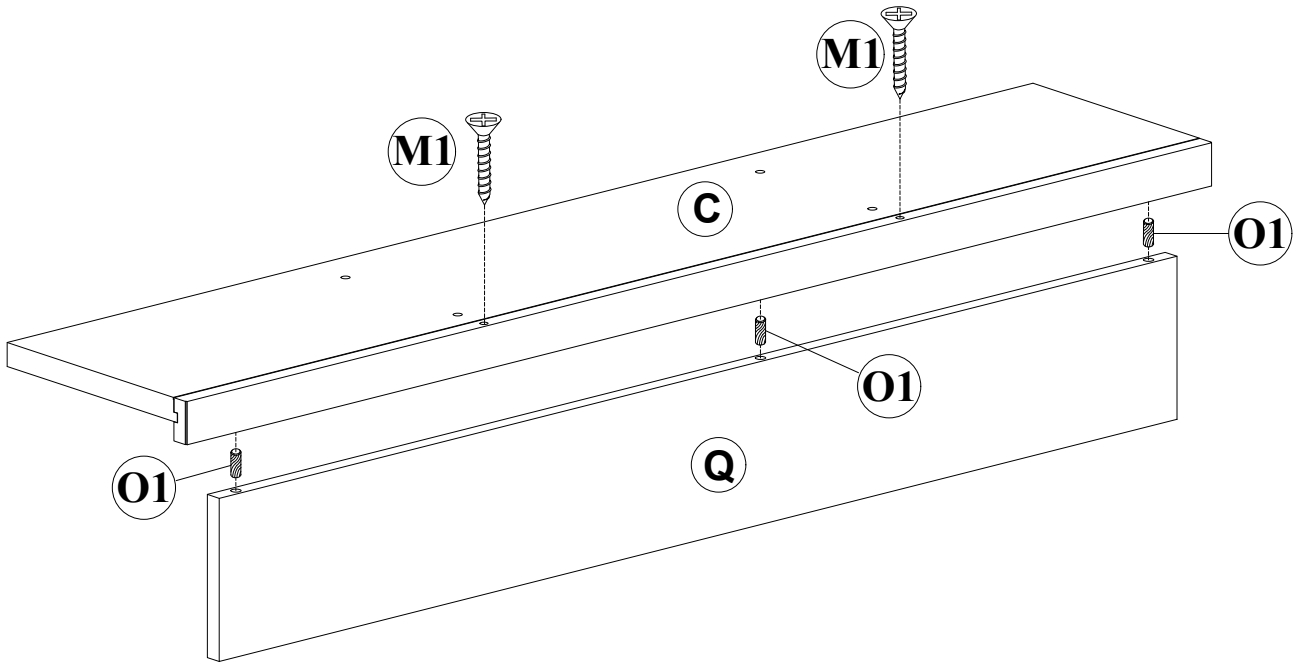

## STEP 2

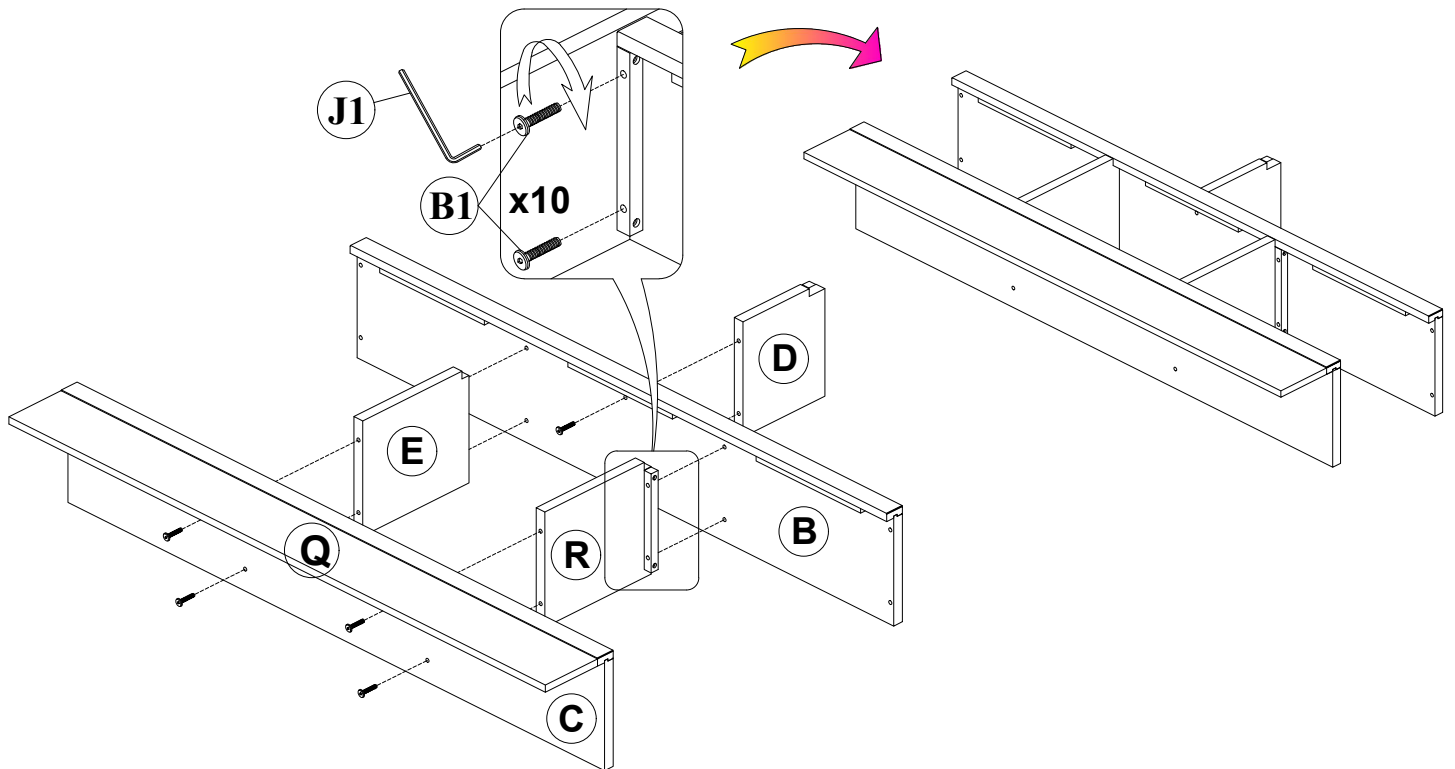

# ASSEMBLY INSTRUCTIONS

## STEP 3

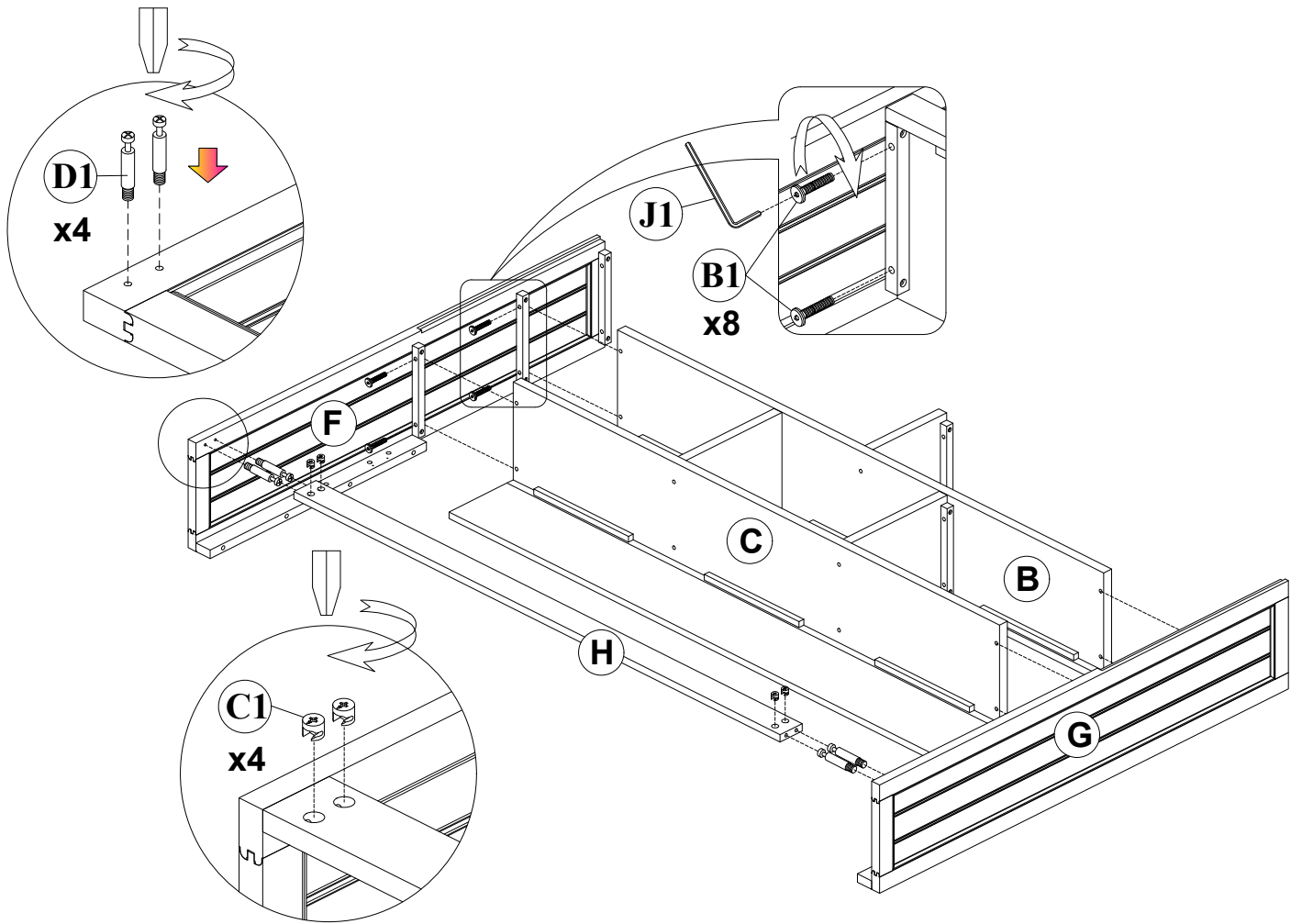

## STEP 4

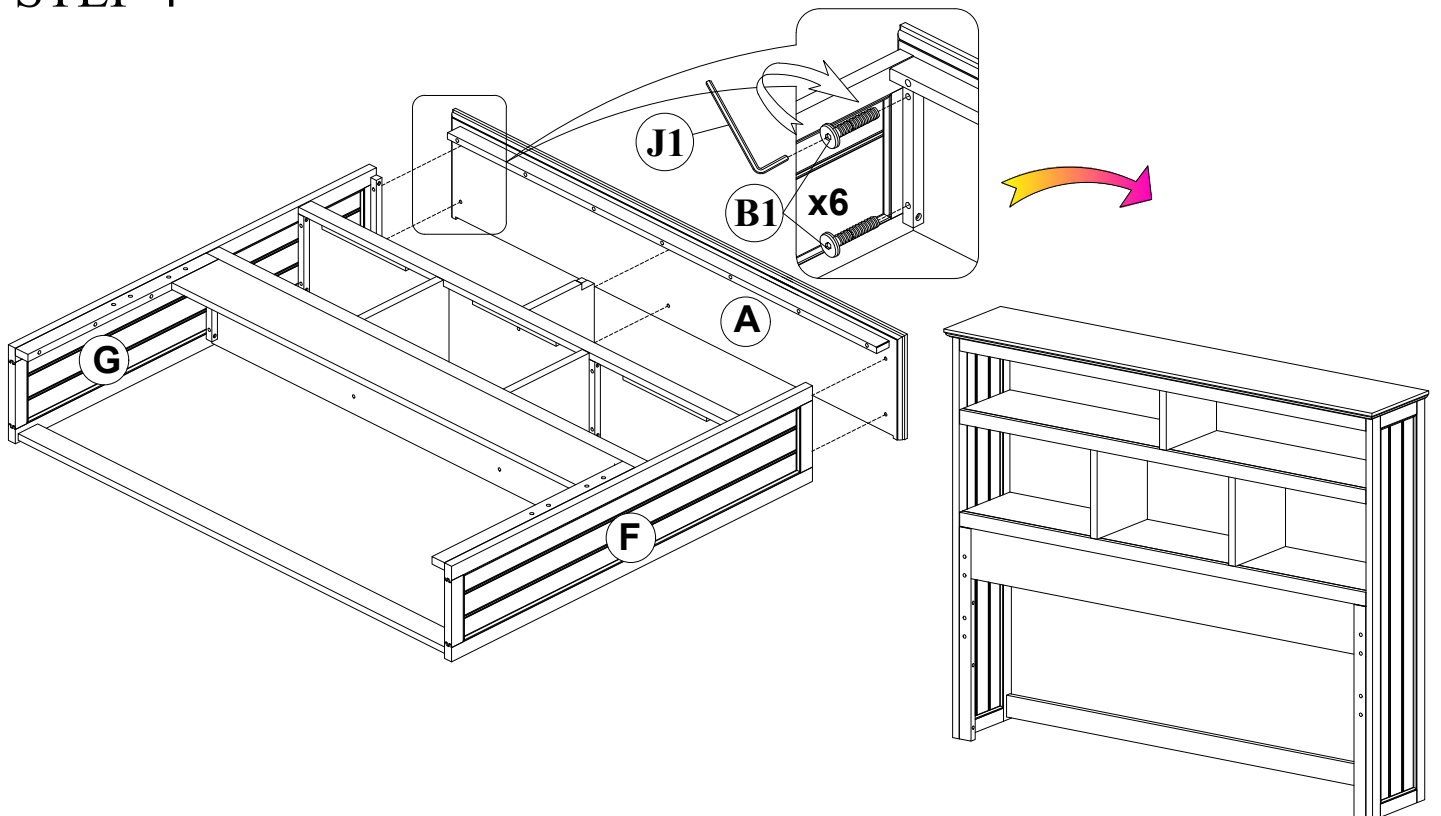

# ASSEMBLY INSTRUCTIONS

## STEP 5

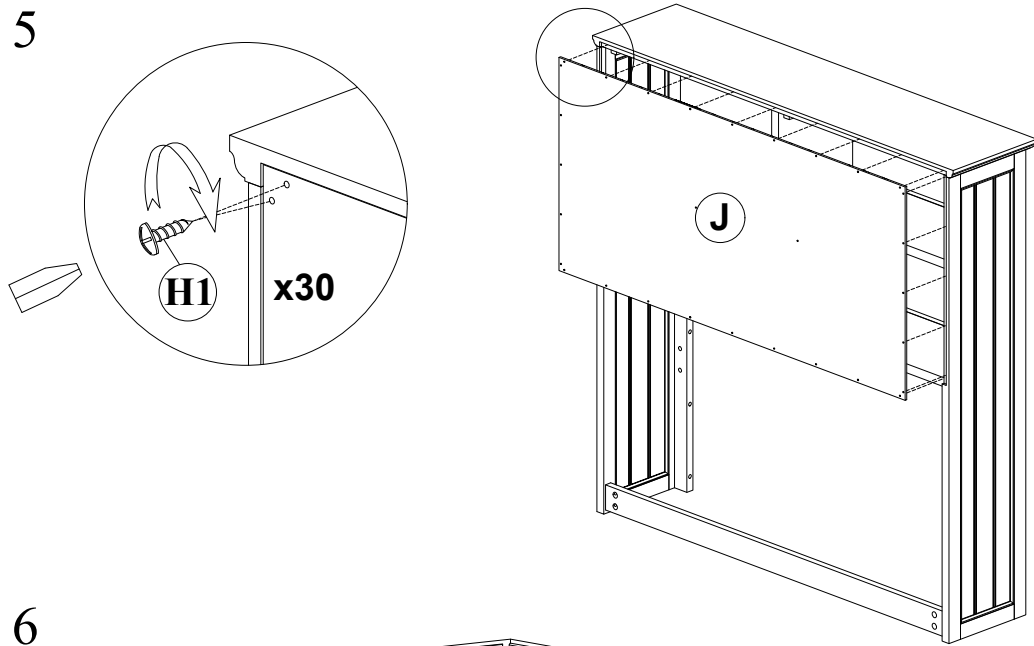

## STEP 6

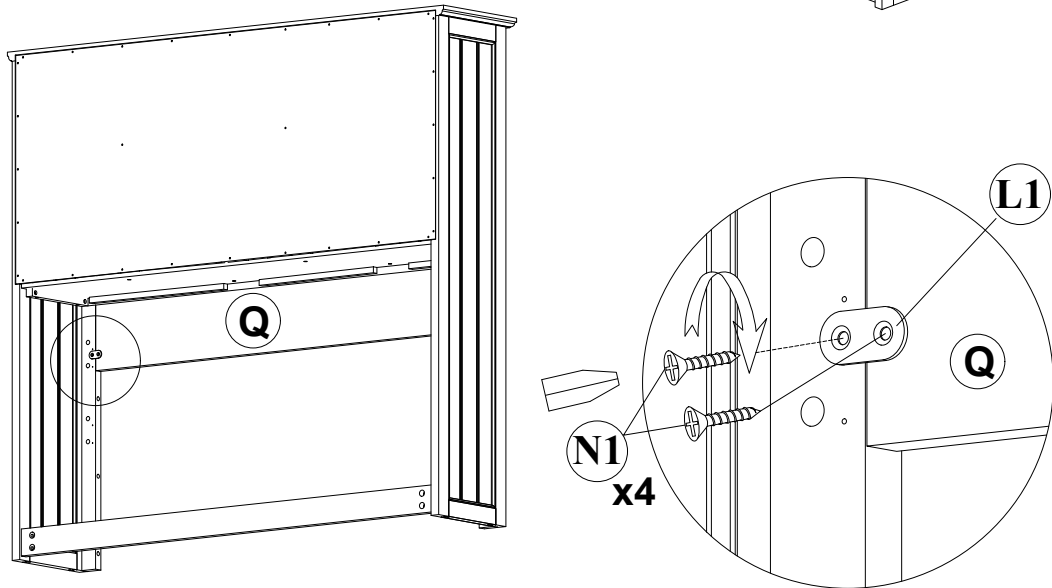

## STEP 7

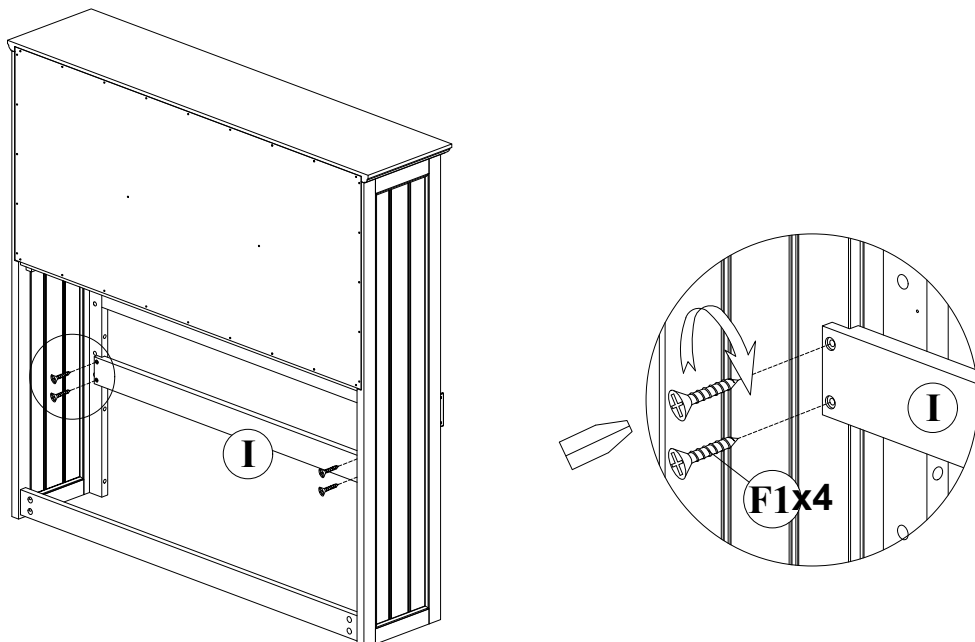

# ASSEMBLY INSTRUCTIONS

## STEP 8

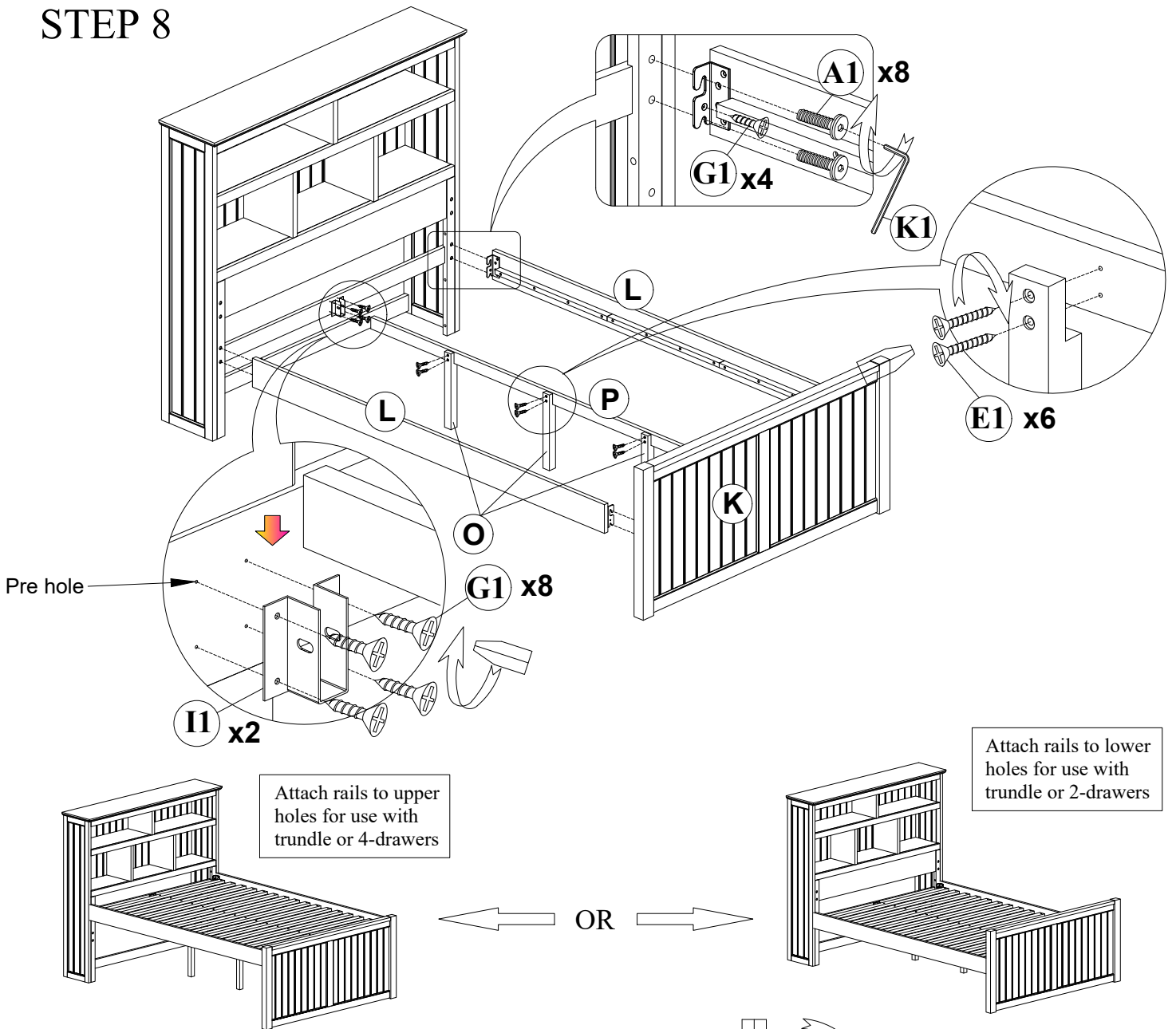

## STEP 9

