

# ITEM: SHORT LADDER

0188/0161-S

0388/0361-S

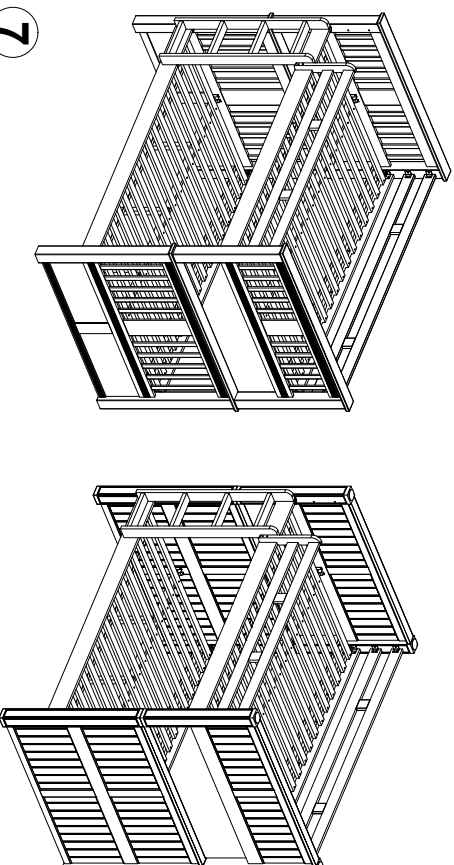

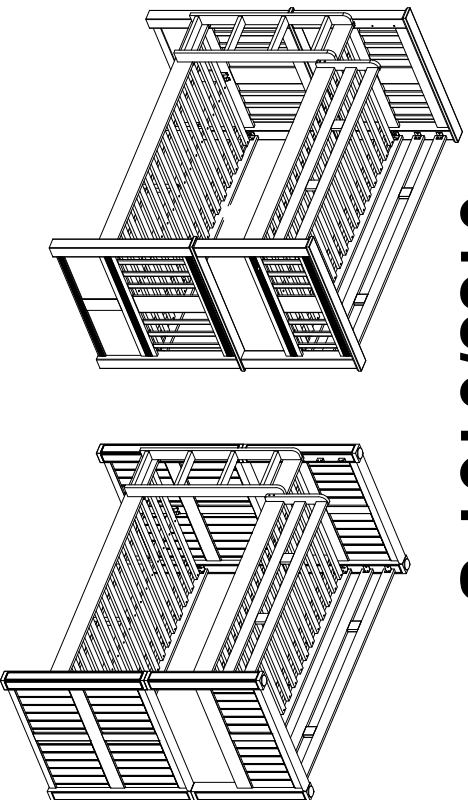



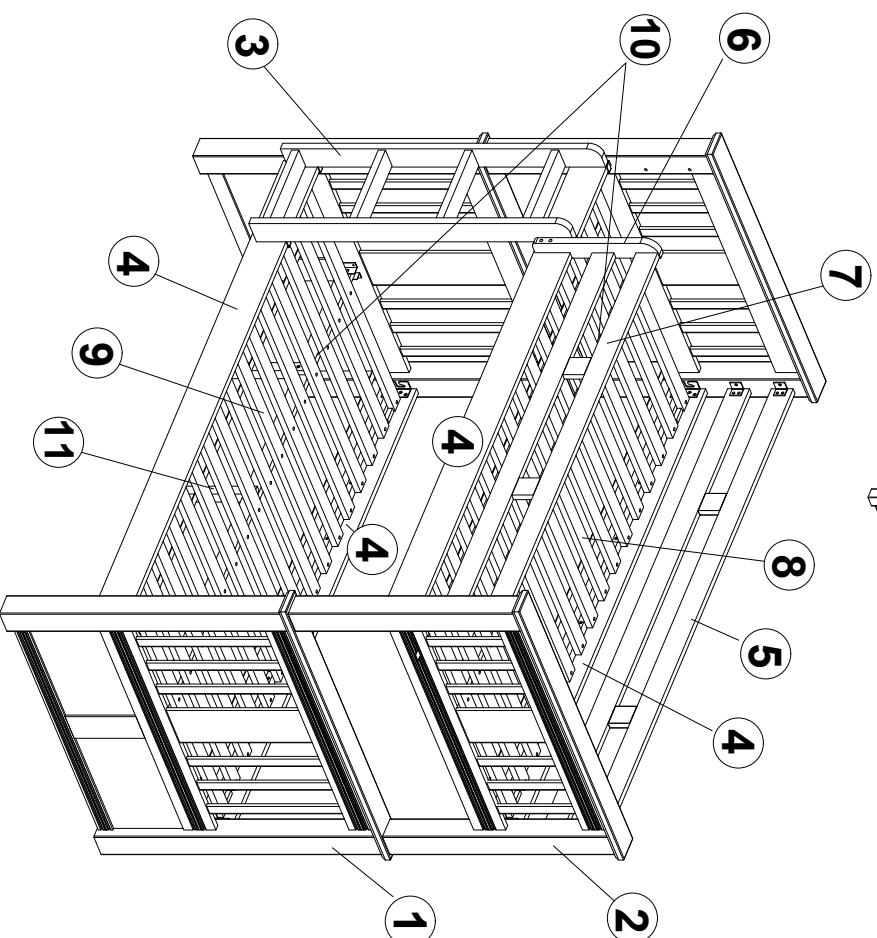



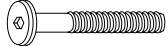

## Part List:

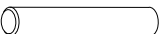
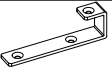
Item	Description	Qty
1	Bottom Head Board & Foot Board	2 pcs
2	Upper Head Board & Foot Board	2 pcs
3	Ladder	1 pc
4	Side Panel	4 pcs
5	Long Guard Rail	1 pc
6	Guard Rail Post	1 pc
7	Short Guard Rail	1 pc
8	Upper Slat	1 set
9	Bottom Slat	1 set
10	Center Support	2 pcs
11	Leg Support	3 pcs

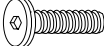

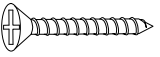
## Hardware List:

Item	Description	Qty
A	JCBC M6 x 60 	2 pcs
B	JCBC M6 x 30 	6 pcs
C	Allen key M4 	1 pc
D	Barrel Nuts 	2 pcs
E	CSK screw M4 x 30 	102 pcs
F	Metal Pin 	4 pcs
H	Ladder Hook 	4 pcs

Item	Description	Qty
I	JCBB M8 x 25 	16 pcs
J	Allen key M5 	1 pc
K	CSK screw M4 x 32 	2 pcs
L	CSK screw M4 x 20 	30 pcs
M	"L" Bracket 	6 pcs
N	"U" Bracket 	4 pcs
Q	CSK screw M4 x 15 	16 pcs

# Step 1

## Bottom Bunk

**DO NOT** TIGHTEN SCREWS BEFORE ALL PARTS ARE FULLY ASSEMBLED !!

Please do not attach leg supports (part 11) if using a trundle.

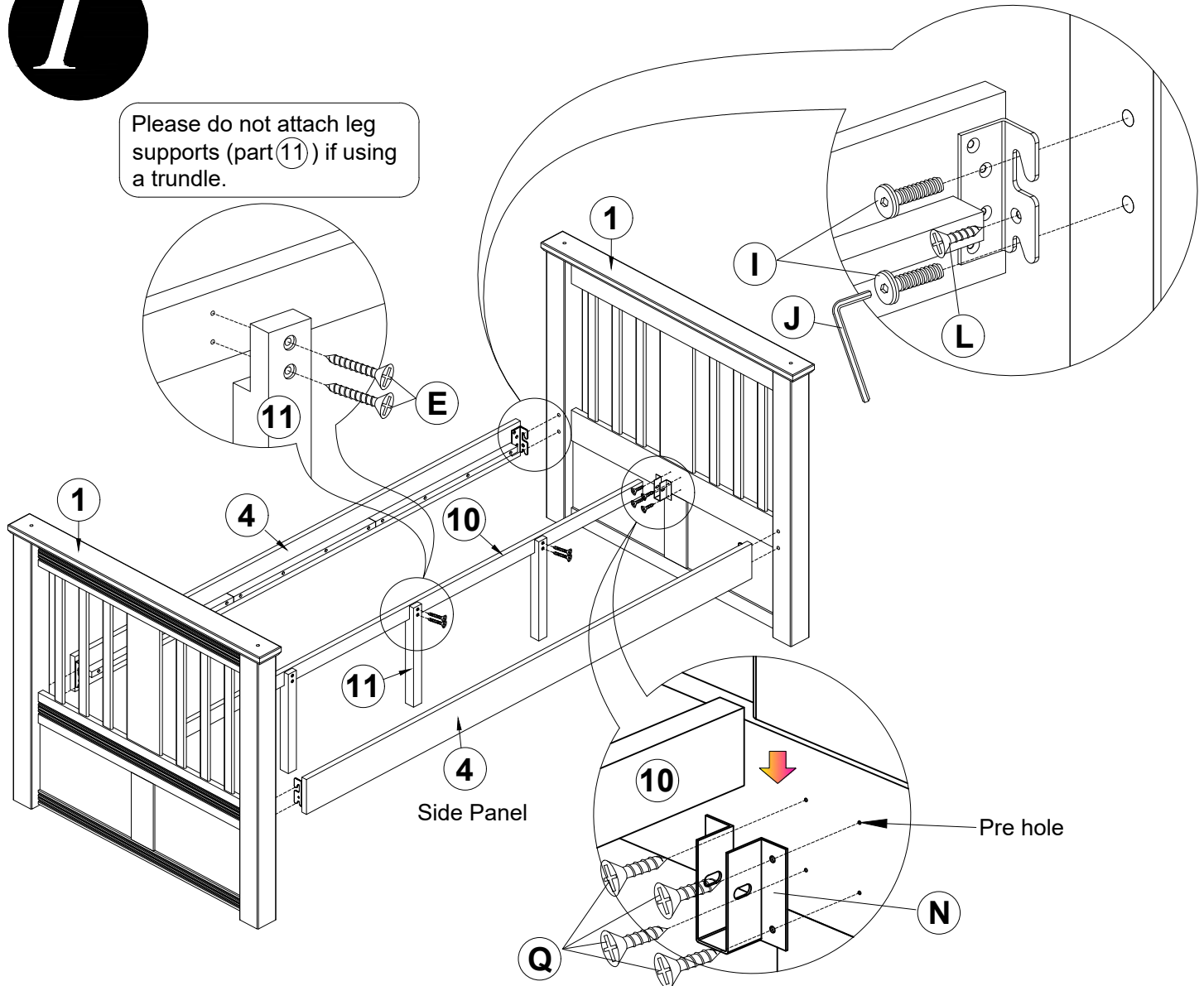

# step 2

These two pre holes are for the L Bracket.

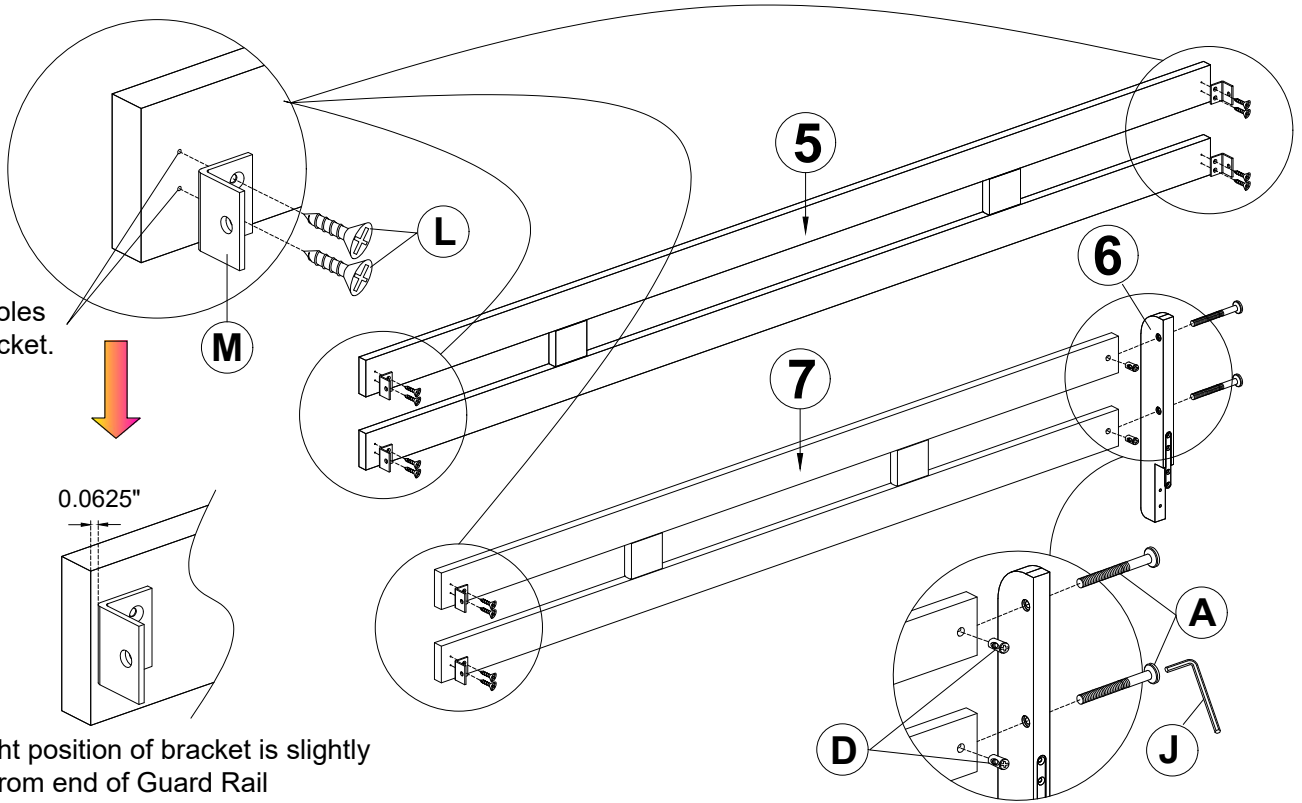

The right position of bracket is slightly inside from end of Guard Rail

# step 3

Top Bunk

\*If there are no pre-drilled holes for the U Brackets (Part N), please place the slat on the base and use the pre-drilled holes on the slat to determine where to place the U brackets. Remove slat prior to attaching U brackets.

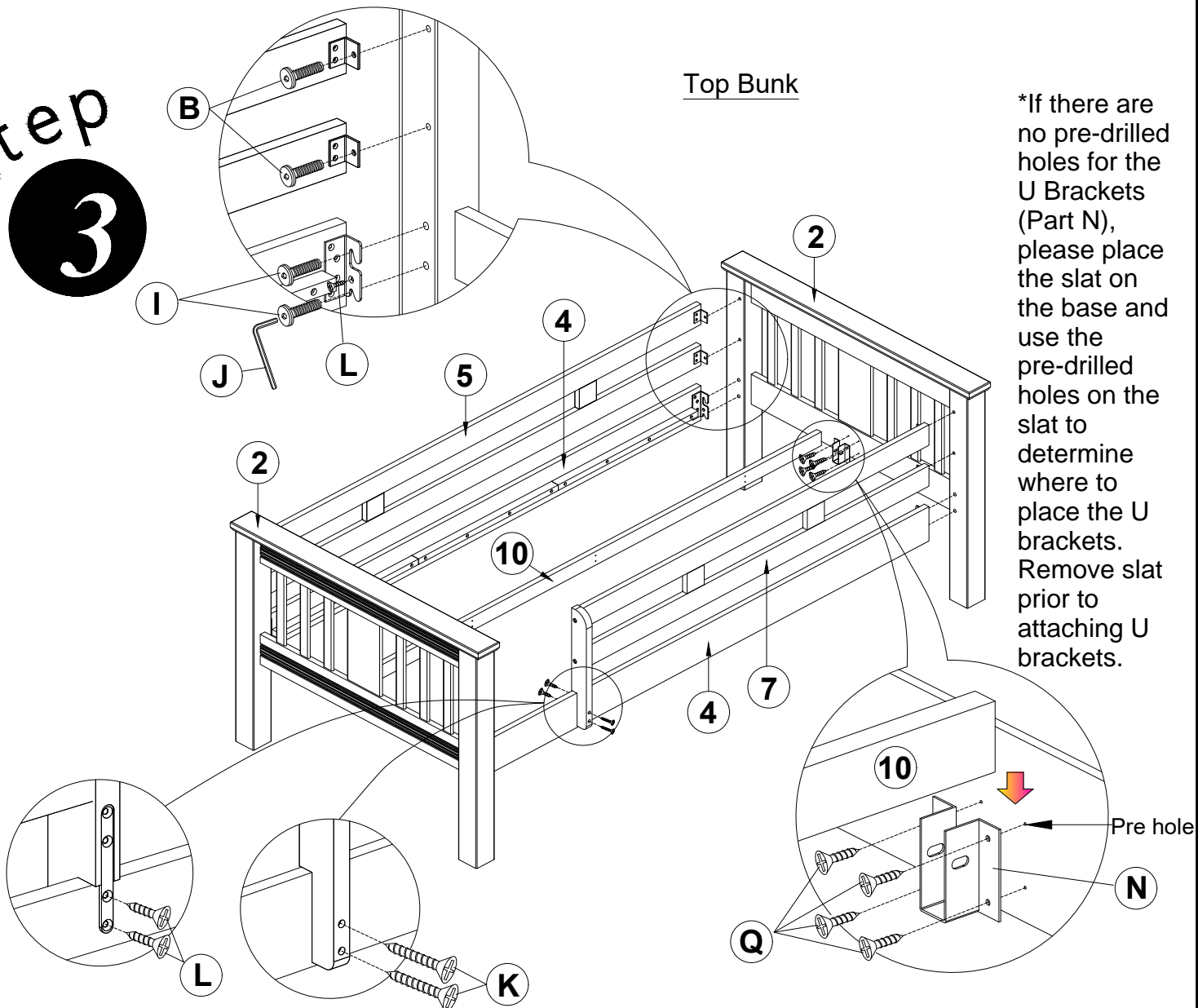

step  
**4**

Install the center support  
(Part **10**) first, then secure  
the slats.

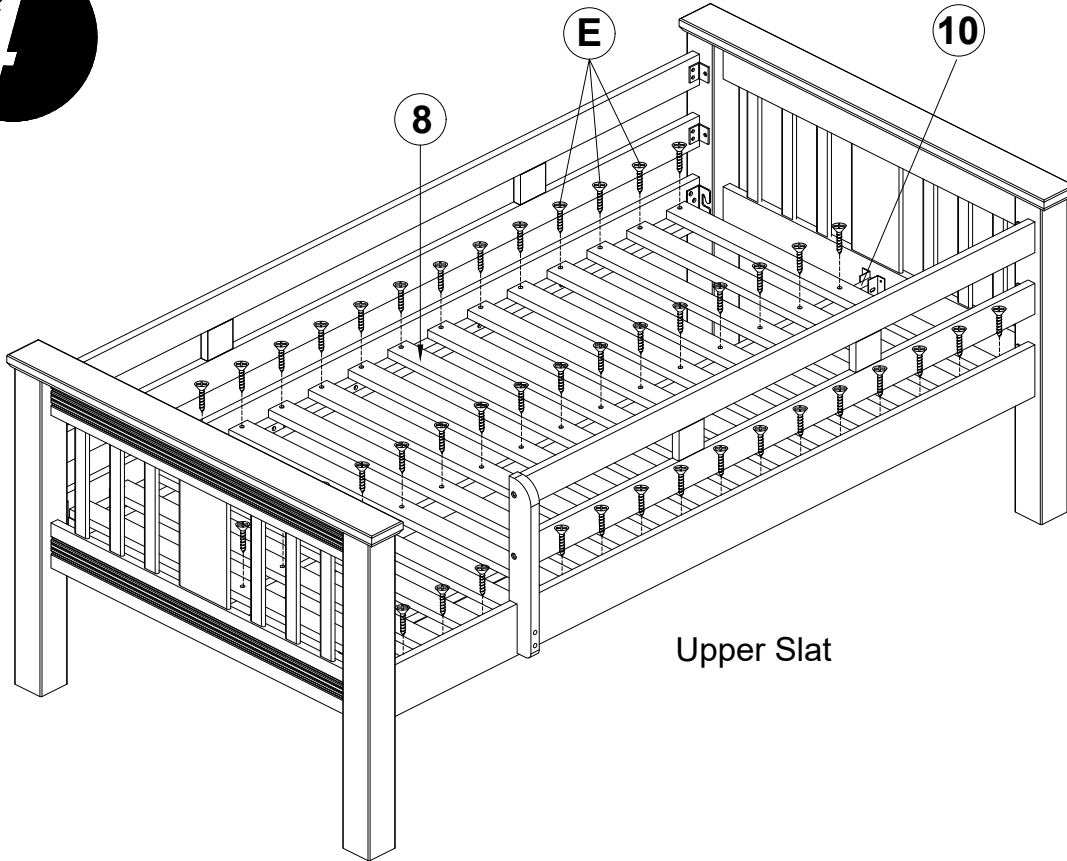

step  
**5**

Install the center support  
(Part **10**) first, then secure  
the slats.

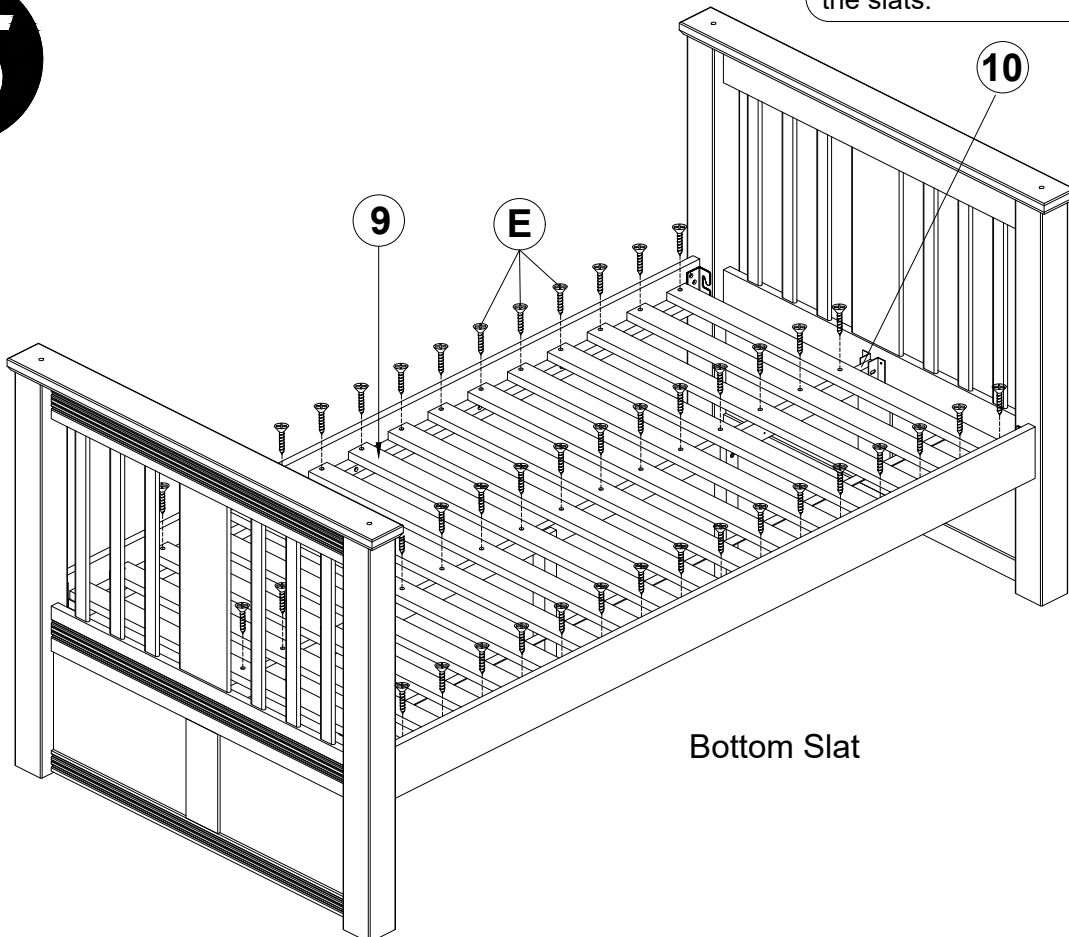

# step 6

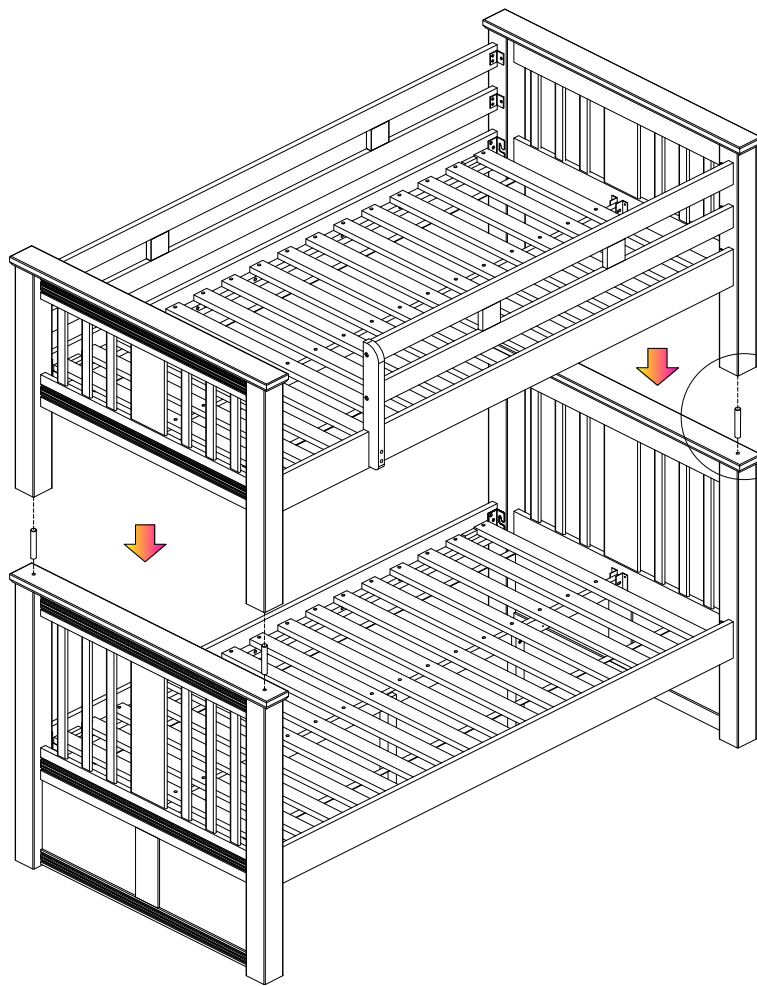

# step 7

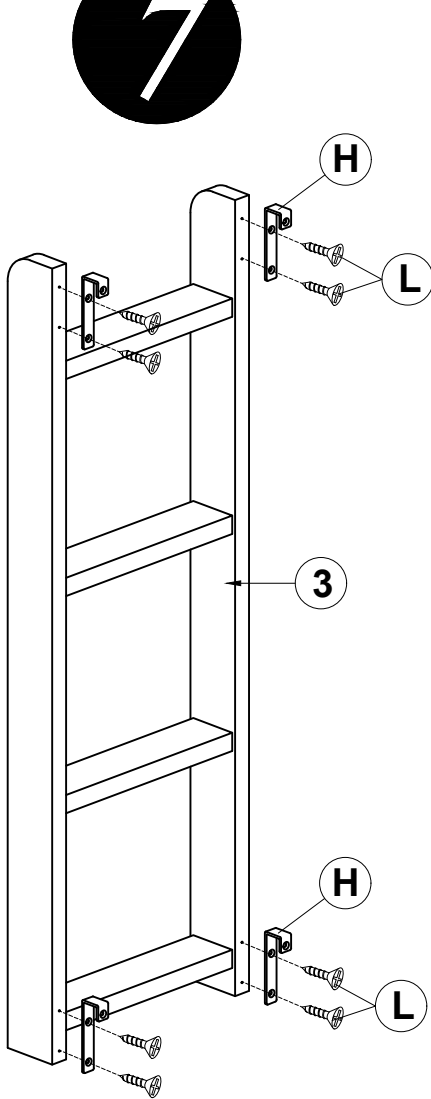

# step 8

